



GOLD ORE

TOMORROW'S TECHNOLOGY TODAY

PATENTED AND PROPRIETARY



At Gold Ore (Pty) Ltd. we've helped metallurgical operations around the world by incorporating the **innovative MACH REACTOR™ technology** into their circuits to improve the extraction of minerals in the most effective way possible.

WHAT IS IT?

The MACH REACTOR™ is a hyper shear mass transfer reactor harnessing the exceptional power of controlled cavitation to generate pico bubbles to greatly enhance the mass transfer of gas into solution and create a highly charged environment promoting chemical reactions that would otherwise not be possible.

The revolutionary MACH REACTOR™ **aids in the extraction of minerals in the most efficient way possible**, helping you to achieve and surpass production targets and improve profit margins.



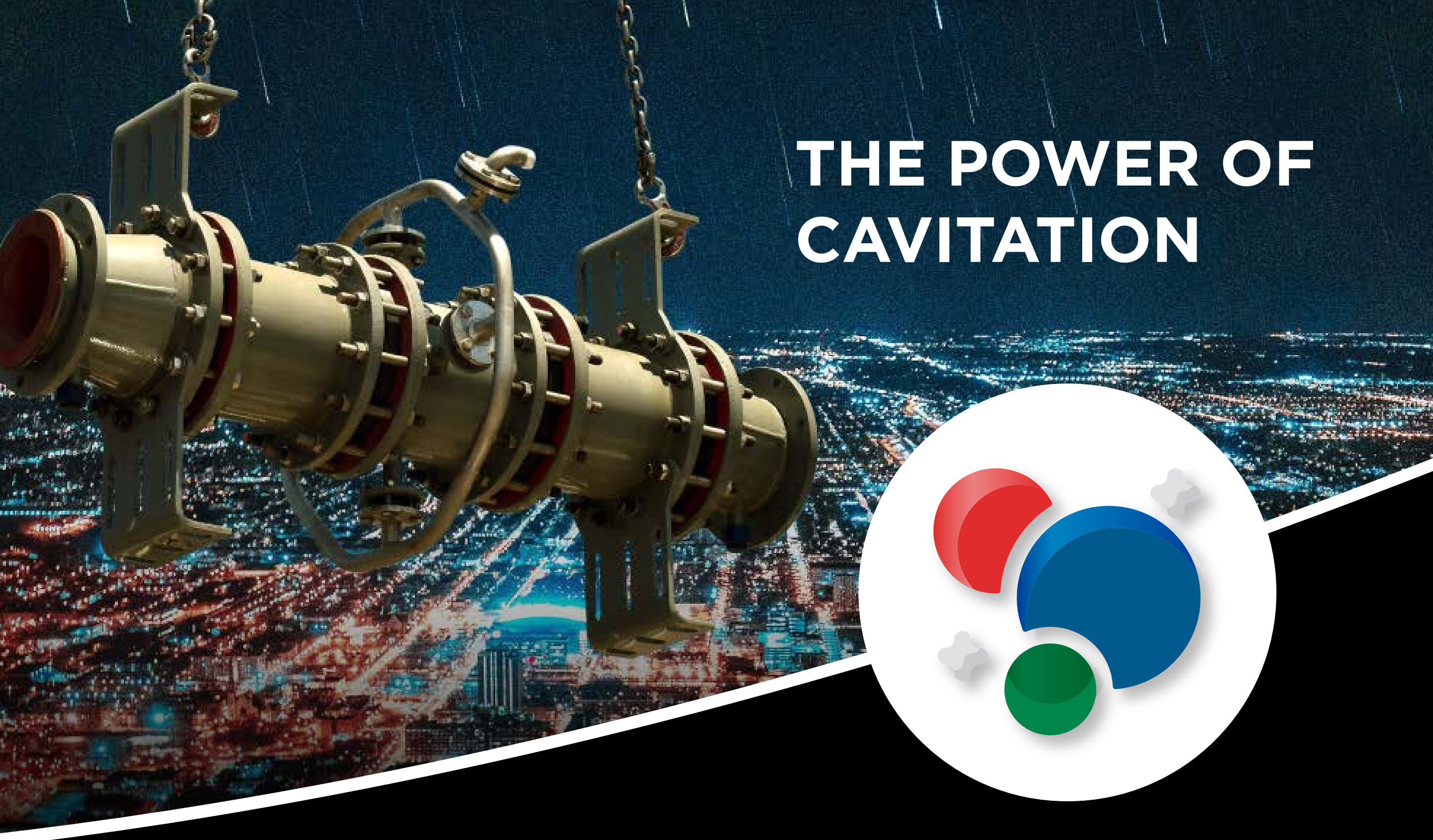

THE POWER OF CAVITATION



Gold Ore has found a way to harness the powerful energy of cavitation and use it for success in metal extraction.

Let's put the MACH into perspective when one considers gas injection devices in the industry. Of lowest efficiency are lances and spargers which have little to no energy input.

Imploding cavitating bubbles generate temperatures up to 5500°C and pressures around 1000 atmospheres creating a highly reactive environment for mass transfer and chemical reaction. Re-entrant jets and the subsequent acceleration of particles and gases in heterogeneous systems approximate the speed of sound, hence the name **“MACH REACTOR™”**.

The MACH REACTOR™ uses a system of venturis to generate **hydrodynamic cavitation**.

Hydrodynamic cavitation is the process of accelerating a liquid through a constriction such as a venturi until the instantaneous pressure drops to below water vapor pressure and causes tiny cavities to nucleate on hydrophobic particles in the liquid.

WHAT ARE THE APPLICATIONS?

MACH REACTOR™ technology finds application across a range of commodities from environmental remediation to metal extraction in hydrometallurgical plants.

The technology may also be employed for conditioning and external aeration in a flotation application. The **MACH REACTOR™** is particularly suited to pre-oxidation and boosted leach applications in gold plants.

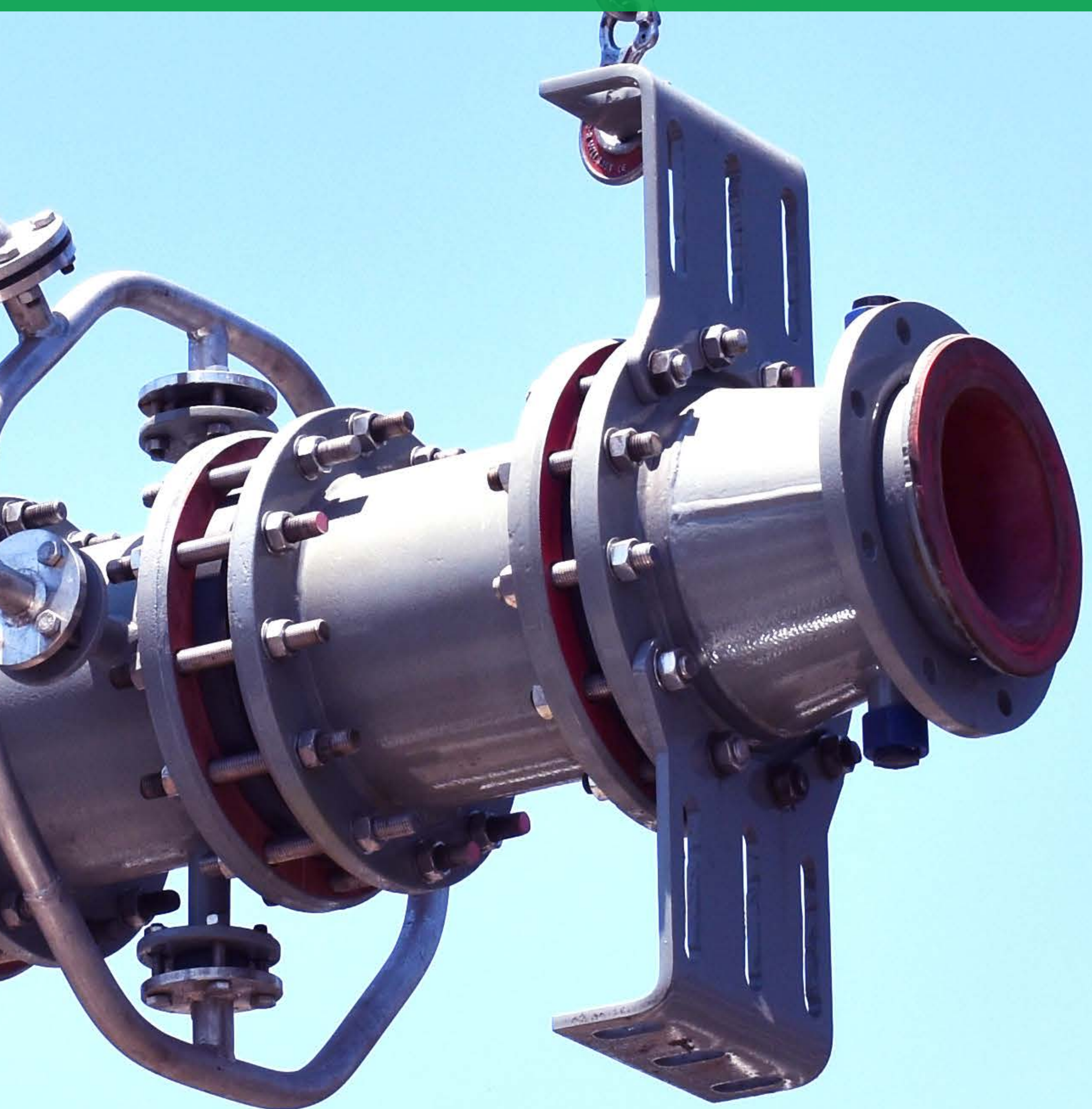

MACH REACTOR™ technology also finds application in the proprietary:

 **Gold Ore Hexate™ Refractory Gold Process**

 **Gold Ore Hybrid™ Detox**

Test work facilities utilizing a scaled down reactor are available at various laboratories across the world. **Stand-alone test rigs are also available for on-site testing.**

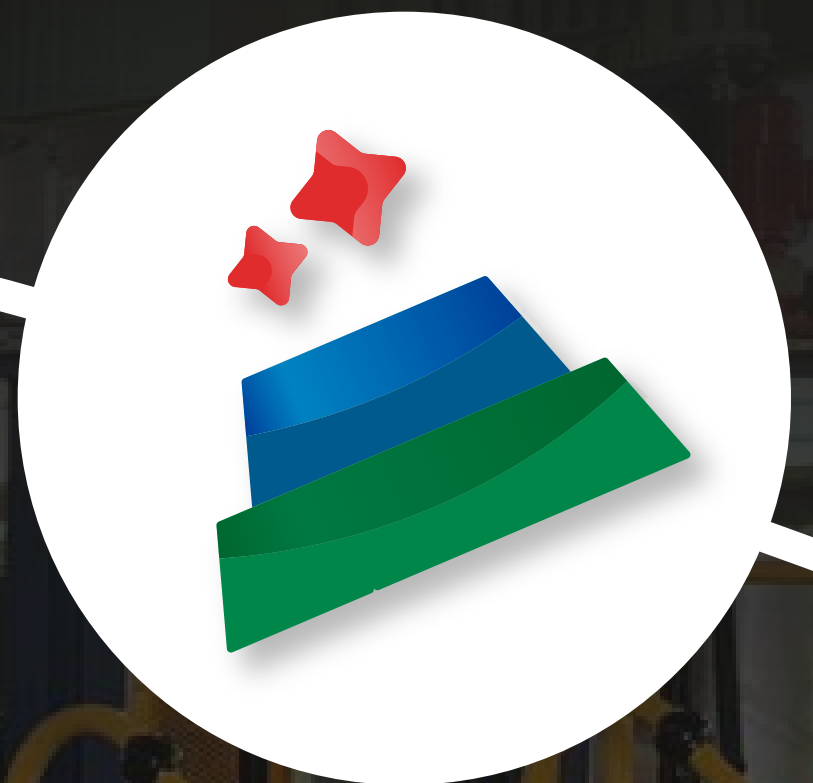

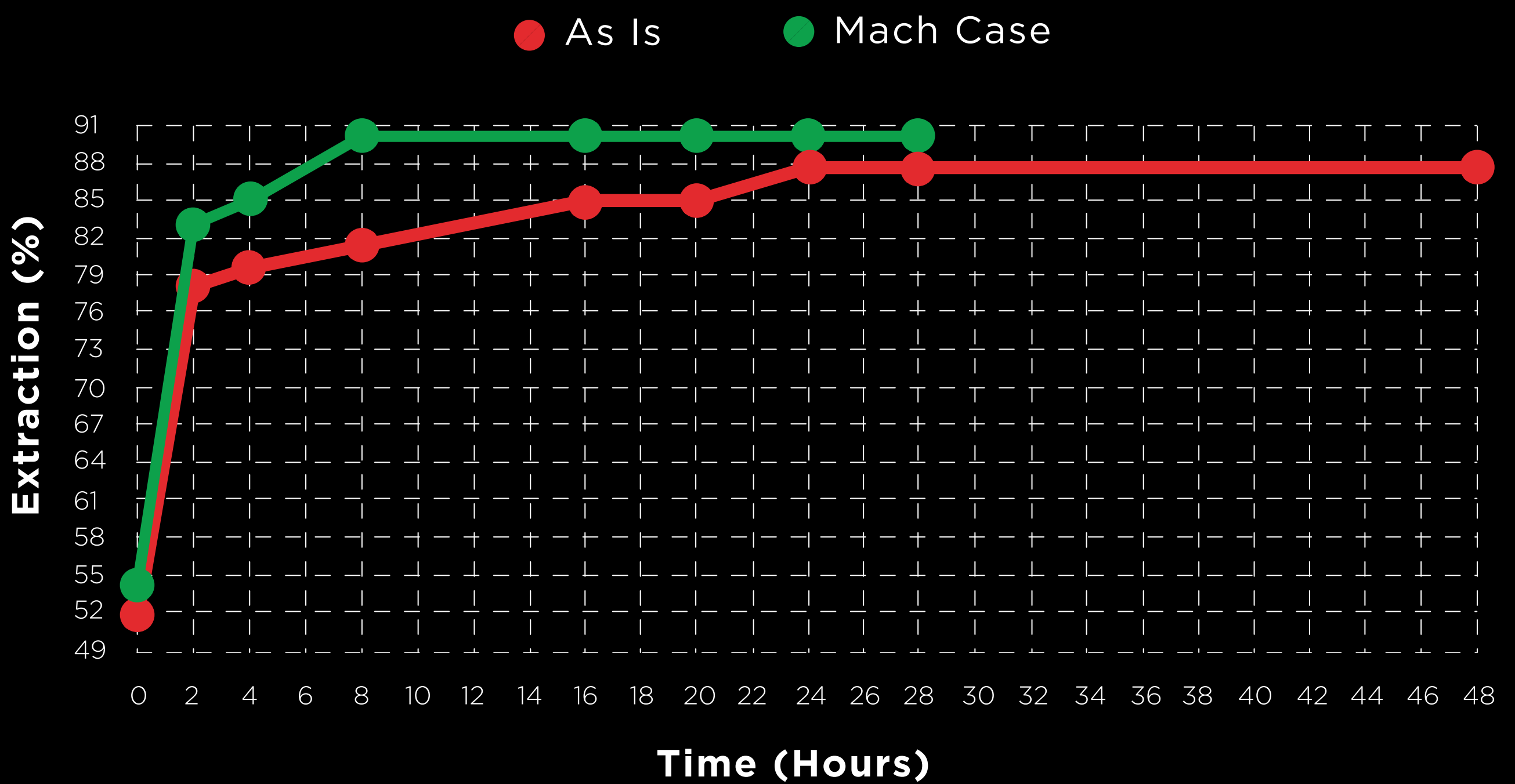

LEACH Benefits

The extraordinary ability of the **MACH REACTOR™** is used to **accelerate leach kinetics as well as overall recovery for gold leach operations.**



Higher recoveries



Faster kinetics



Reduced reagent consumption

Through the effective flotation of well liberated and high-grade fines with the **MACH REACTOR™**, we are able to provide a completely new and steepened grade recovery curve where **both grade and recovery is improved, resulting in flotation euphoria!**



Higher grades



Higher recoveries



Lower mass pulls



FLOAT Benefits

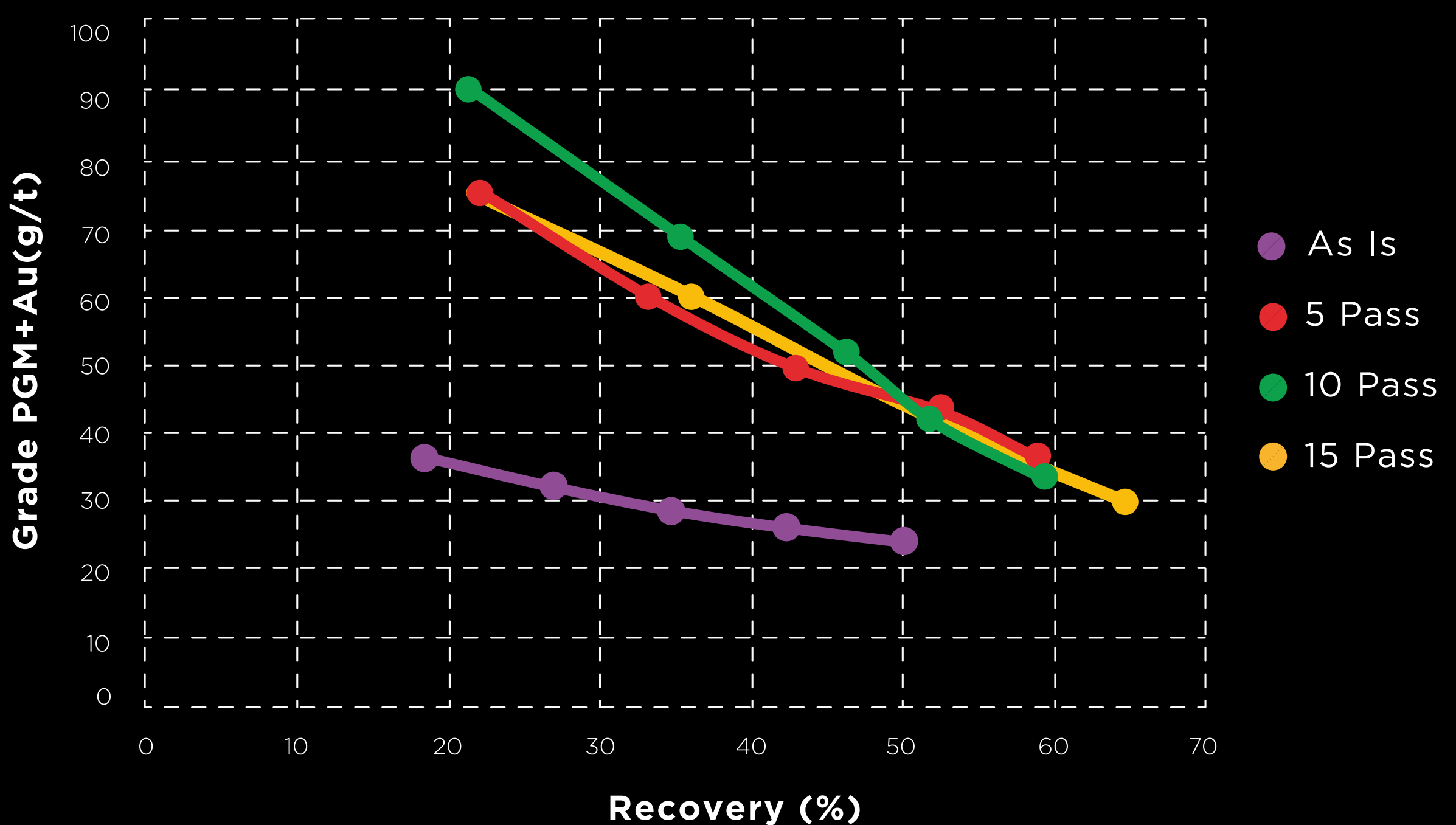



DESIGN Benefits



Self-aspirating enabling low pressure gas injection



No moving parts



Highest quality ceramic lining of high wear sections



Non corrosive and chemical resistant body



No maintenance



Reactor life to match project life

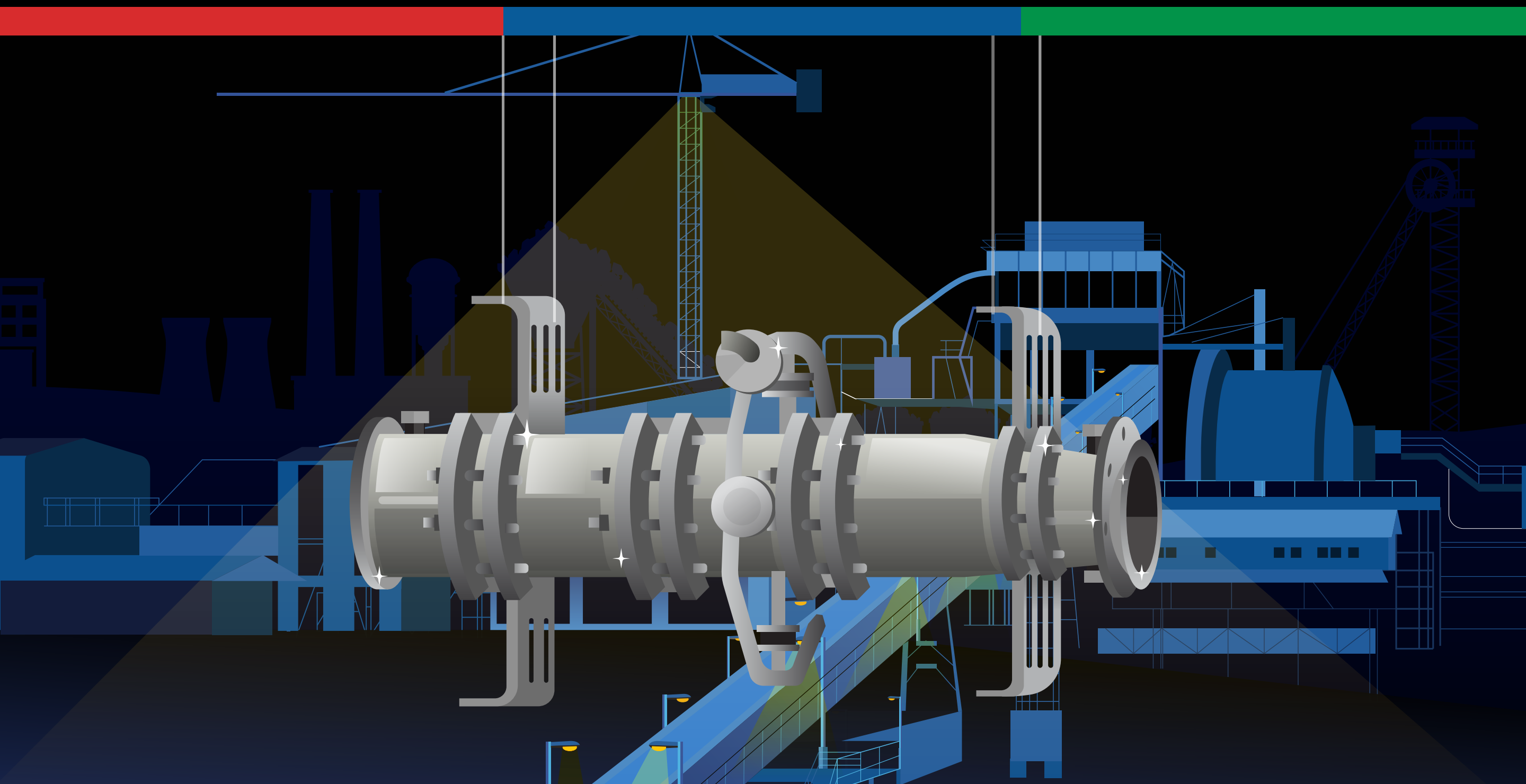



Customizability Options

- ✓ **Ceramic**
- ✓ **Mild steel**
- ✓ **Stainless steel**
- ✓ **Rubber, or**
- ✓ **Plastic (or a combination of these)**

Available MACH REACTOR™ range in size from as small as 0.45m³/h for a laboratory unit to as large as 3000m³/h through a single unit.

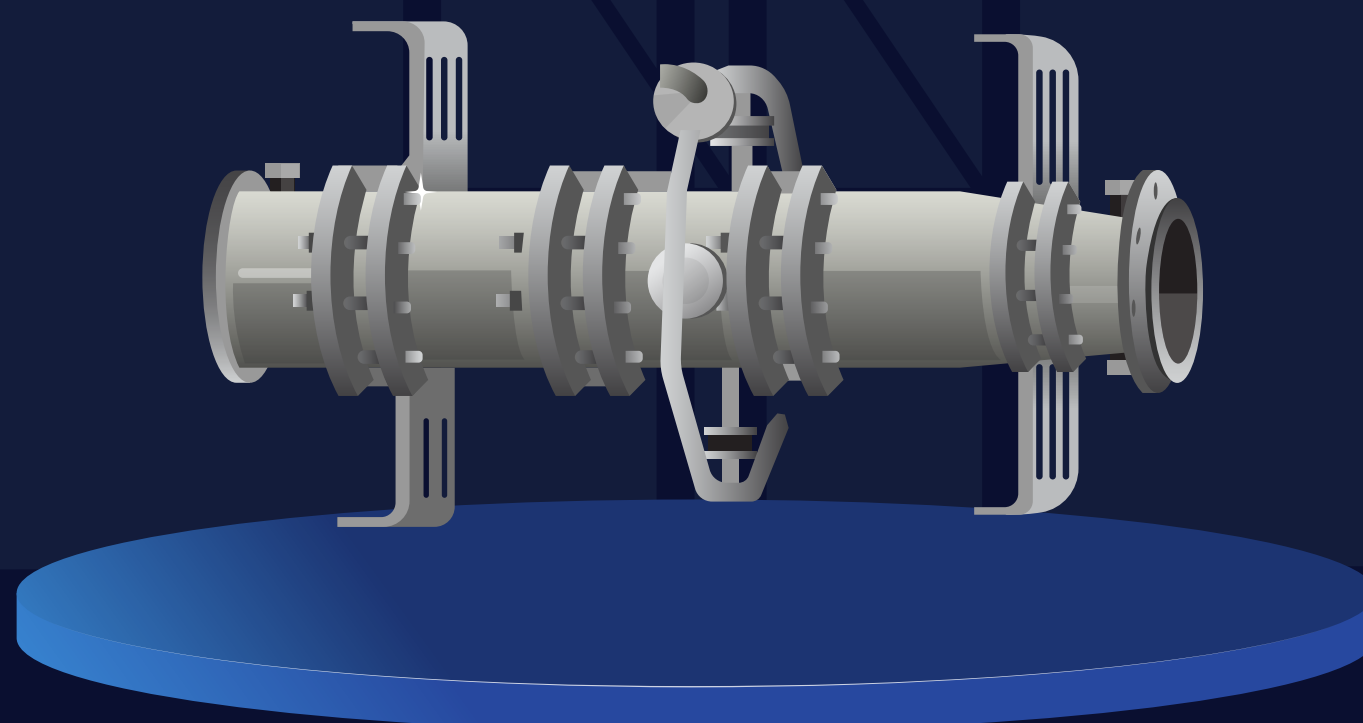

CERAMIC



MILD OR
STAINLESS
STEEL



CAPACITY



STAINLESS
STEEL



RUBBER

WHAT GIVES IT THE EDGE?

The **MACH REACTOR™** is currently the only high shear device currently on the market that is completely self-aspirating allowing it to be operated without a pressurized gas supply. At worst case, it can be installed to draw in air from the atmosphere, making state of the art technology accessible to all projects. **It is also the only shear reactor unit with a reactor life to match project life.**

The self-aspiration aspect, combined with the comparatively lower power draw, makes it particularly suitable to projects where power costs are high, or power is self-generated.



INSTALLATION OPTIONS

Gold Ore operates internationally.



LEACH TANK (TOP VIEW)

1, 2 AND 3 IS THE DIFFERENT OPTIONS OF MACH POSITIONING
(IN ORDER OF PREFERENCE - DIRECTLY OPPOSITE THE PUMP SECTION IS MOST PREFERRED)

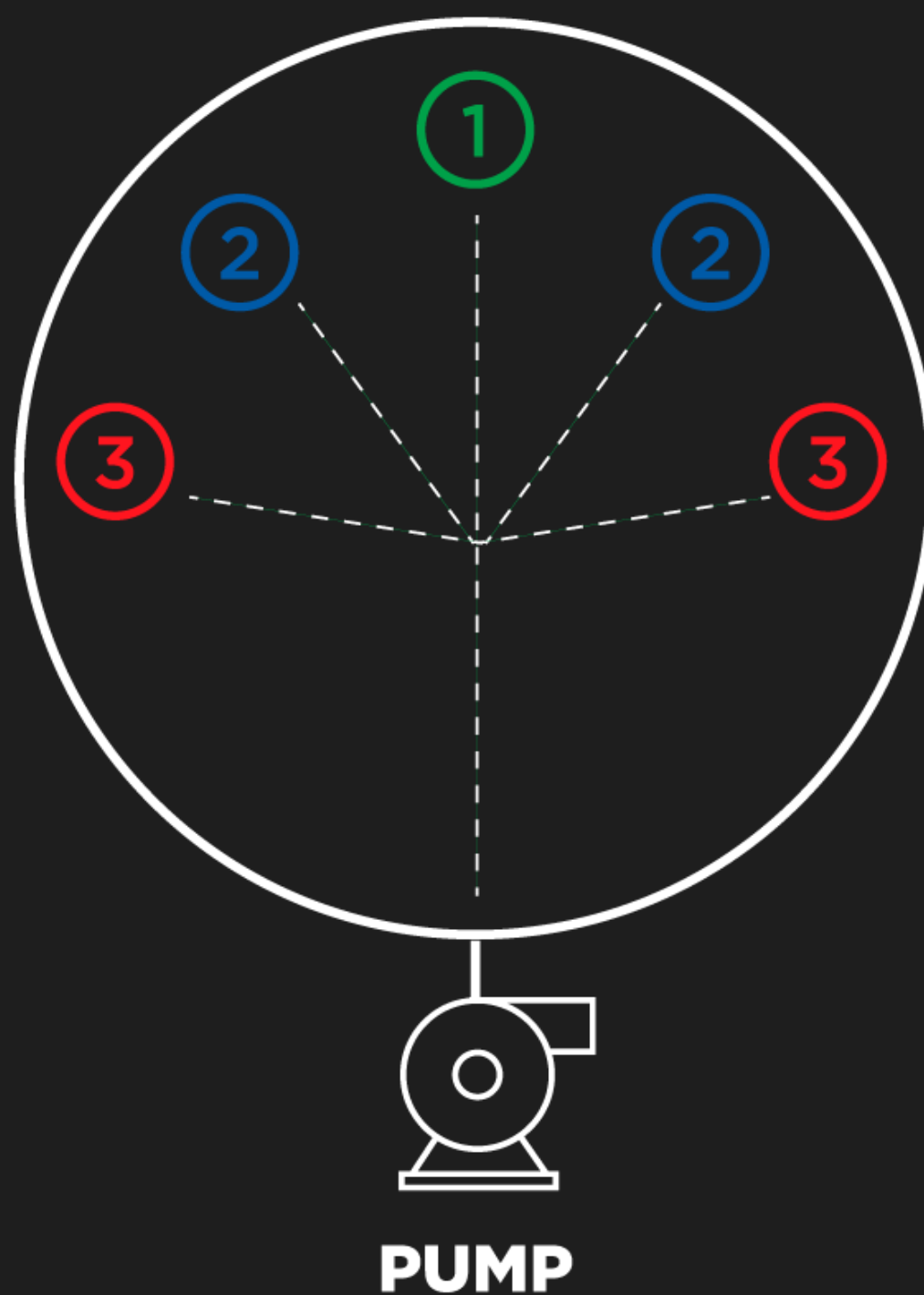

NEEDLE TANK SCHEMATIC (SIDE VIEW)

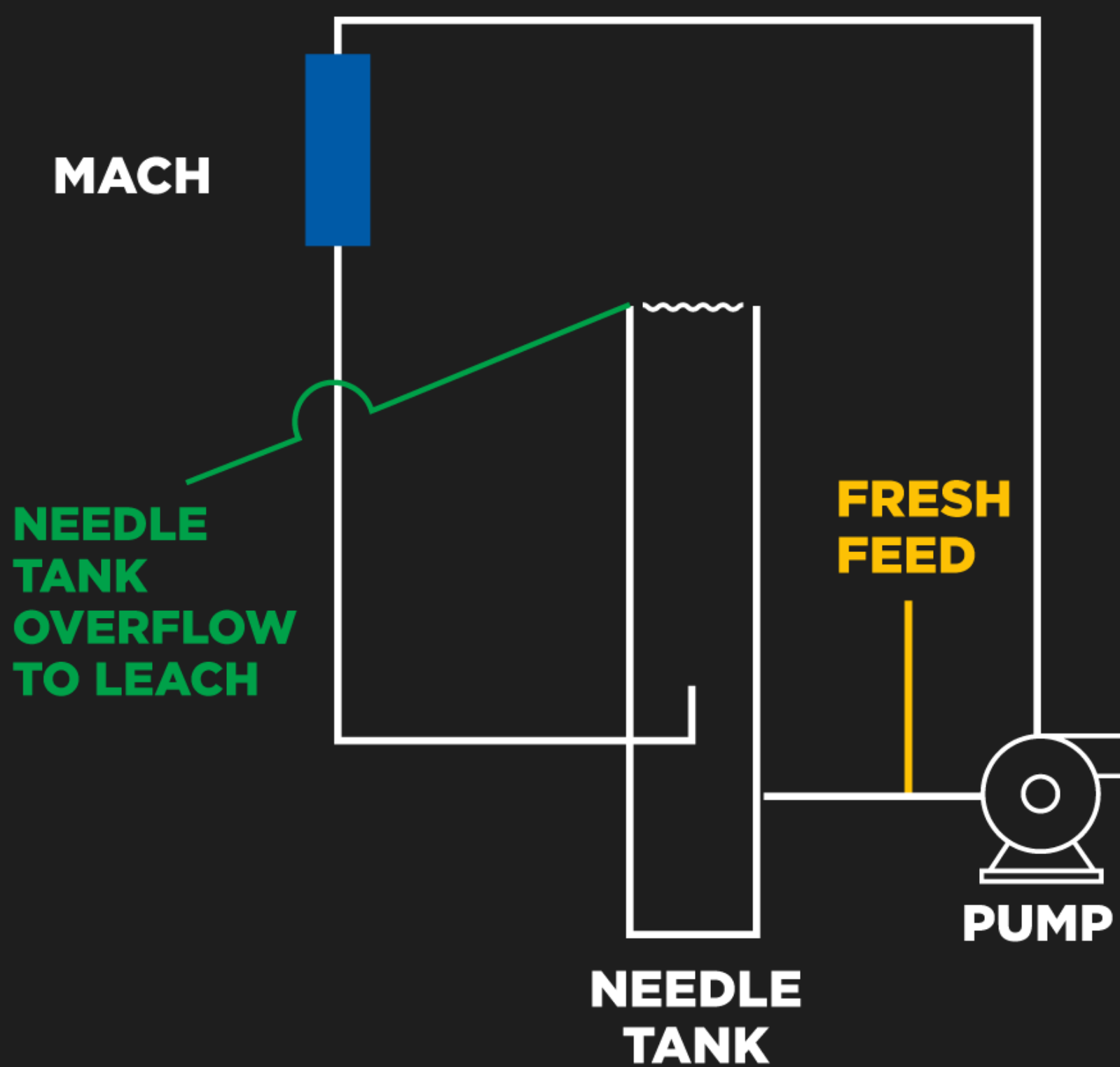

The MACH REACTOR™ can be installed in-line with the flow into the first Leach Tank or on Tank Recycle (preferred).

IN-LINE INSTALLATION (SIDE VIEW)

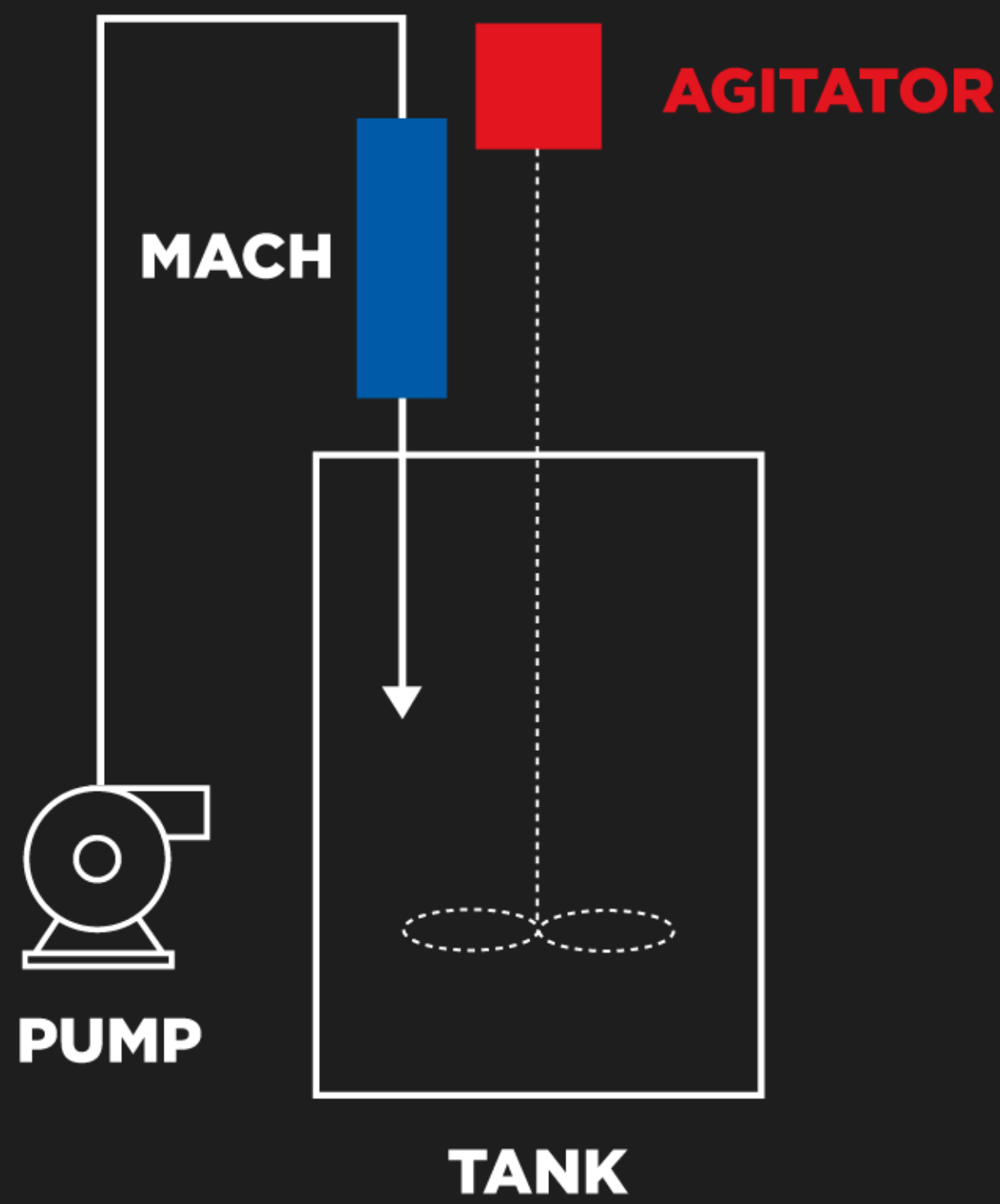

TANK RECIRCULATION (SIDE VIEW)

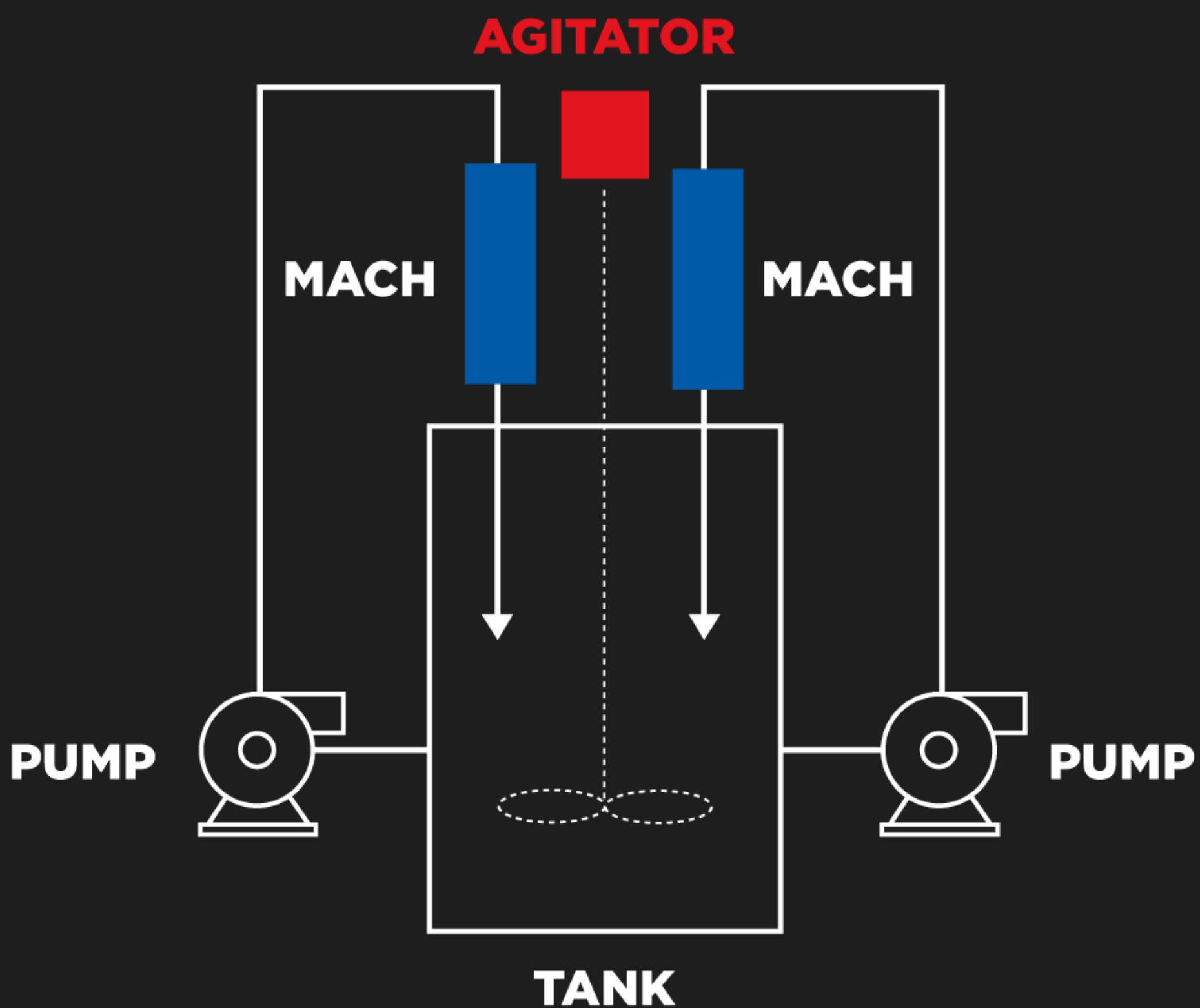



**PROUDLY SOUTH AFRICAN
TECHNOLOGY**

**EXTRACT MORE OUNCES WITH
THE MACH REACTOR™!**

ADRIAN SINGH B. Sc., MMMA, SAIMM
Director

2 Cascades, Russel Street, Benoni, 1501
Reg. No. 2012/189353/07

+27 (0) 82 940 7057

adrian@goldore.org

www.goldore.org

